

PRACTITIONER'S MANUAL

DAW Industries

50S0 Ultra-Lite™

5-Bar Stance Flexion & Custom-ICR™ Stability

Stock #: TGK-50S0

IMPORTANT:

Adjusting alignment beyond recommended limits described within will adversely affect patient's gait, and could cause premature wear.

HEADQUARTERS:

6610 Nancy Ridge Road
San Diego, CA 92121-2252
Orders: (800) 252-2828 • (858) 622-4962
Fax: (800) 856-8563
www.daw-usa.com

Technical Support
(800) 242-8669

**CENTRAL/EASTERN
DISTRIBUTION CENTER:**
5579-B Chamblee Dunwoody Road
Suite 227
Atlanta, GA 30338-4154
Orders: (800) 824-7192
Fax: (800) 865-8563



50S0 Ultra-Lite™

5-Bar Stance Flexion & Custom-ICR™ Stability

Stock #: TKG-50S0

Engineered for K2 individuals of fair capability

Benefits:

- ✓ Durable Ultra-Lite carbon fiber construction
- ✓ 5-Bar Custom-ICR adjustable geometric stability
- ✓ Precise Stance Flexion adjustment (0° to 15°)
- ✓ Proven durability & reliability
- ✓ Trouble-free, zero maintenance
- ✓ Separate extension & flexion adjustments
- ✓ Forever-smooth stainless ball bearing axes



IMPORTANT:

Read technical information thoroughly before using knee.

Popular Proximal Options

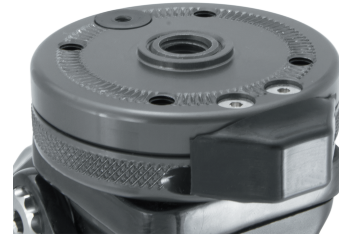

Lo-Pro Rotator™

(#: TKR-01)

Provides Rotational Adjustment
Attach any 4-Hole connector

Suggested L-Codes*: **L5984**



4-Hole Female Pyramid w/ Rotation, Titanium (#: GUPT-F4HROT)

Provides Angular & Rotational Adjustment

Browse our complete selection of Unique Components at

daw-usa.com/all-connectors

Recommended K2 Foot



K2 Feather-Lite™ Foot

Engineered for the K2 Individual Requiring mobility & safety

Provides 2 Flexible Keel Options &
Multi-Axial Ankle Motion with Rotation

Suggested L-Codes*: **L5972** **L5986**

*Please refer to the complete reimbursement disclaimer at www.daw-usa.com



DAW®
Industries

© Copyright 2021, DAW Industries, San Diego, CA - All Rights Reserved 01272021



DAW®
Industries

© Copyright 2021, DAW Industries, San Diego, CA - All Rights Reserved 01272021

Specifications

Contents

Patient profile:

Body weight	Under 275lb (125kg)
Functional level	K2
Amputation level	Transfemoral, Bi-lateral or Hip Disarticulation

Knee Specifications:

Stock number	TGK-50S0
Max weight limit	275lb (125kg)
Knee weight	1.67lb (760g)
Swing controls	Friction Adjustment with Forever-Setting™, Extension Assist Adjustment & Swing Phase Trigger Adjustment
Stability controls	Custom-ICR™ Stability Adjustment & Stance Flexion Stability
Proximal connection	M6 threaded 4-hole or, Unthreaded single hole
Distal connection	30mm tube clamp
Warranty	2 years, upgrade for additional 3 years

Page

Recommended Order of Adjustments	1 (Below)
Build Height	2
Torque Settings	2
Alignment	3
Custom-ICR™ Stability Adjustment	4-5
Stance Flexion Adjustment.	6
Swing Phase Friction Adjustment with Forever-Setting™	7
Extension Assist Adjustment	8
Replacing or Trimming the Extension Assist Spring	9
Extension Stop (Stability & Swing Phase Trigger Point)	10
DAW Prosthetic Knee Limited Warranty	11
Specifications.	12
Popular Proximal Options	(inside back cover)

ADJUSTABLE FUNCTIONS

Recommended Order of Adjustments

1. Static Custom-ICR Stability adjustment
-adjust to residual limb length
2. Stance Flexion Stability
3. Dynamic Custom-ICR Stability adjustment
-fine tune to Patient's capability
4. Swing Phase Friction
5. Extension Assist
6. Extension Stop



BUILD HEIGHT

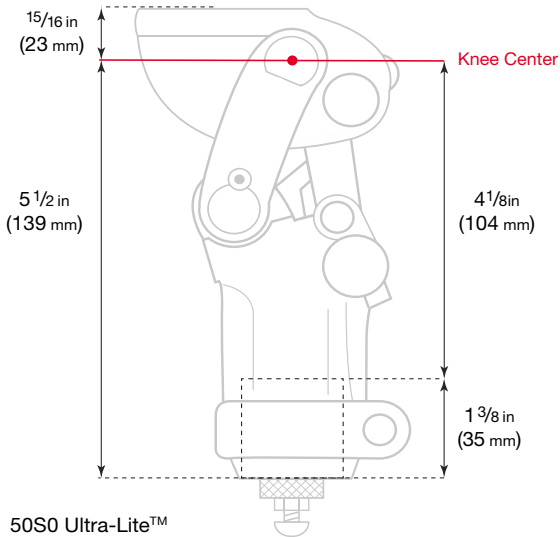

TORQUE SETTINGS

Important:

Use blue Loctite™ 242 on all screws referenced here.

It is not recommended to use Ottobock Titanium Pylon. Do not use a spacer for height adjustment. Ensure pylon is cut straight.

It is recommended these torques be checked within 30 days and then 6 months after your delivery of this prothesis.

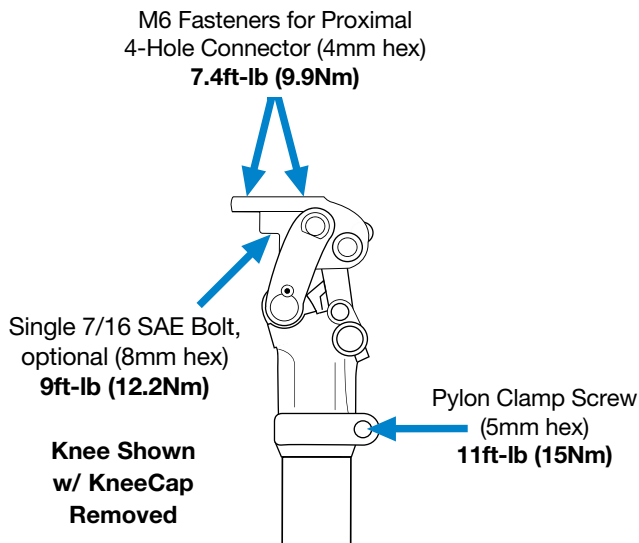

For Technical Support call (800)242-8669

© Copyright 2021, DAW Industries, San Diego, CA - All Rights Reserved 01082021

DAW Prosthetic Knee Limited Warranty

The knee comes with a Limited Warranty for 2-years. It covers manufacturer defects (excluding wear & tear). An additional 3 years of warranty coverage can be purchased for +15% of the original cost of the knee. See full warranty statement at:

www.daw-usa.com/practitioner-resources/

Weight limit of this knee is 275lb (125kg)

Bumpers are not under warranty.

Tight screws and a straight cut of the tubing are a must. Not following recommended use of components, including weight limit and alignment, will void the warranty. Make sure to read all instructions enclosed with the knee unit.

All repairs on the knee module must be done by a factory-trained DAW technician. Any disassembly done on the knee during the warranty period(s) will void the warranty (excluding disassembly of the extension spring housing).

Service Under Warranty

For all component repairs call DAW Industries right away. We will ship a replacement knee the same day, which will become your patient's new knee. The replacement component is under warranty for the time remaining on the original component.

The overnight shipping charge will be credited upon receipt of the failed knee component.

Service Outside of Warranty

Knees not under warranty may be repaired by DAW. While any unwarranted knee is being serviced, DAW will provide a rental knee subject to availability. The DAW rental fee is listed in the price list under each knee. The rental fee covers the period DAW takes to complete the repair with ten (10) days allowed for shipping in both directions. The same rental fee will be charged every 30 days passed the initial rental fee period.

For any repair you must first contact our Technical Services at 1(800)242-8669. This will allow DAW to best understand the issue. Our Technical Support will immediately assess if the repair qualifies as a "minor" or "substantial" repair. A "minor" repair will be completed, as a courtesy, free of charge (you will just pay for return shipping). A "substantial" repair will be billed at a flat rate according to knee model. Upon return of your repaired knee, you will be invoiced for the repair charge, if any. When DAW receives the rental knee, your account will be credited for the value of the returned knee (Gold Preferred+ = FREE rental; Preferred = 33% off).

In the event your knee is unrepairable, you will be notified immediately. The rental must then be returned to DAW, 2nd day, within five (5) working days. The rental fee may be applied toward the purchase of a new DAW knee.



For Technical Support call (800)242-8669

© Copyright 2021, DAW Industries, San Diego, CA - All Rights Reserved 01082021

Adjusting the Extension Stop Bumper

(Stability & Swing Phase Trigger Point)

Adjusting the Extension Stop Bumper will affect both the Knee's Stability and "Trigger Point" of Swing Phase. The maximum adjustment is 2°.

NOTE: This adjustment will affect socket flexion slightly.

Adjusting the Extension Stop Bumper Screw:

- A. Flex the knee and remove the Kneecap Screw (3mm hex), and remove the Kneecap.
- B. Loosen the Set Screw (2mm hex)
- C. Turn the Extension Stop Bumper Screw (6mm hex)
 - Clockwise** for less stability (& earlier swing-phase initiation)
 - Counter-clockwise** for more stability (& later swing-phase initiation)
- D. Retighten the Set Screw (**Hand Tighten**).
- E. Replace the Kneecap when your Swing Phase Trigger Point setting is satisfactory (**Hand Tighten**).

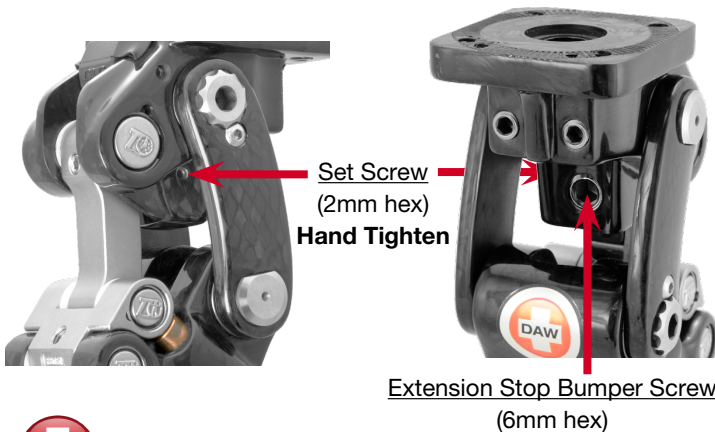

RECOMMENDED BENCH & STATIC ALIGNMENT

Standard alignment procedure must be observed to obtain the maximum benefits offered by this knee. All alignment references should be taken from the center of the anterior superior knee axis (commonly referred to as the Knee Center).

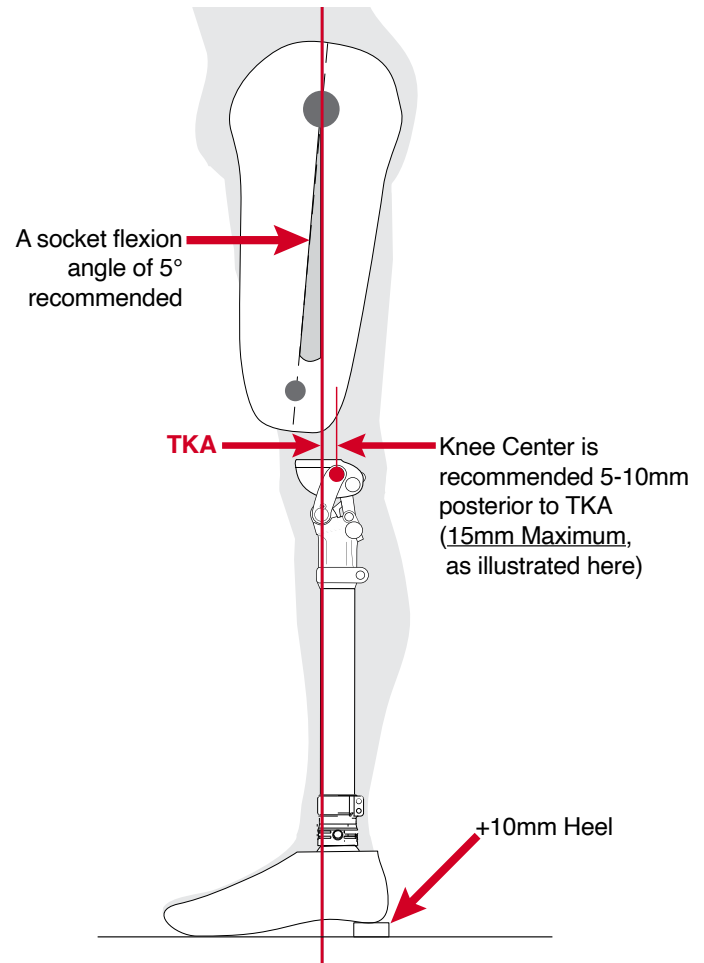

Why is Custom-ICR™ Better?

Improve Stability without Altering Alignment

Without affecting your alignment, the Custom-ICR™ Stability Adjustment optimizes the location of this knee's ICR to improve stability and minimize energy consumption (see next page to optimize your Patient's Custom-ICR setting).

Watch the "Custom-ICR Setting" video at daw-usa.com/videos

What is a 4-Bar Knee's ICR? And why is its location important?

A Polycentric knee's **Instantaneous Center of Rotation** or **ICR** is a theoretical point located at the intersection of 2 lines which pass through the axes and continue proximally (see fig. below).

The **ICR** location of different polycentric knees determine 2 important aspects of your patient's gait:

- The Level of Inherent Stability the knee provides (measured by the **ICR's** distance from TKA or Force Vector)
- Your Patient's energy consumption.

Why is an Adjustable ICR Position advantageous?

A traditional 4-Bar knee's **ICR** location is not adjustable. If it is located too far posterior for your Patient's individual biomechanics, your Patient will consume excessive energy.

DAW 5-Bar Knee's let you optimize Inherent Stability to your patient's needs while also minimizing their energy consumption.

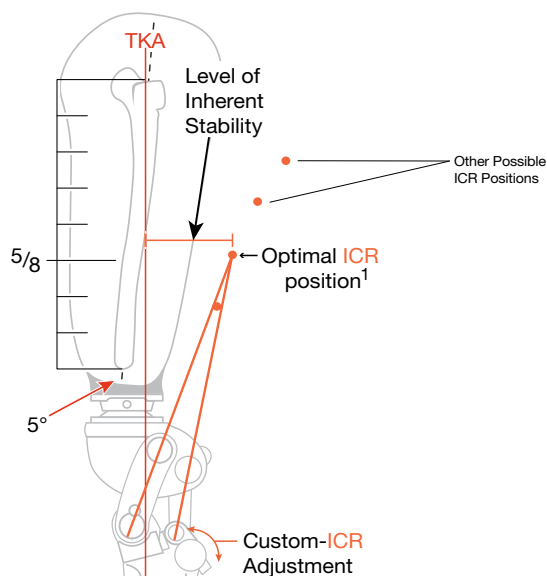

¹ The optimal location of the **ICR** is the area where the Amputee applies force to their socket wall during stance phase. It is most commonly, $\frac{5}{8}$ down the length of the femur.

Replacing or Trimming the Extension Assist Spring

To replace the Extension Assist Spring:

- Loosen the Pylon Clamp Screw (5mm hex).
- Remove the pylon.
- Completely remove the Extension Assist Control Screw ① (5mm hex).
- Feed a 2.5mm hex key through the holes of the Spring Housing ②. Using the torque provided by the hex key, unscrew the housing.
- Pull the white Piston ③ out of the housing. The Spring ④ is pressed on the Piston's distal end.
- Unclip the Piston and Force Plate ⑤ from the Spring, transfer them to your new Spring. Return the Spring Assembly, Force Plate end down, to the housing.
- Re-screw the Housing into the knee, hand tighten.
- Re-screw the Extension Assist Control Screw back in until you feel it make contact with the Force Plate (this is your new minimum setting).



To trim the Extension Assist:

Follow steps A. through E. above, then,

Unclip the Force Plate ⑤ & Piston ③ from the Spring.

Using a grinding wheel, trim one or two coils (maximum) off one end of the spring. Smooth the trimmed end. Press the Force Plate into the mouth of the housing. Press the Piston onto the uncut end of the Spring. Return the Spring & Piston to the housing, **trimmed end down**, pushing the Force Plate down into the housing.

Continue with steps G. and H. above.

Adjusting Extension Assist

To Adjust Extension Assist:

- A. Loosen the Pylon Clamp Screw (5mm hex) and remove the Pylon
- B. Loosen the Lock Nut (12mm wrench)
- C. Turn the Extension Assist Control Screw (5mm hex):
Clockwise to increase extension assist
Counter-clockwise to decrease extension assist
- D. Re-tighten the Lock Nut, **Hand Tighten** (12mm wrench). After returning the pylon, re-tighten Pylon Clamp Screw to **11ft-lb (15Nm)**.



Adjusting Custom-ICR™ Stability

Your Patient's optimal Custom-ICR Stability setting considers 2 important biomechanical traits:

1. Femoral length and
2. Hip extensors strength

During Bench or Static Alignment:

Adjust the setting to your patient's residual femoral length.

- A. Loosen the Set Screw (2mm)
- B. Turn the Custom-ICR Adjustment (5mm hex):
 $\frac{1}{4}$ turn **clockwise** for every inch of femur shorter than 8.
 or...
 $\frac{1}{4}$ turn **counter-clockwise** for every inch of femur longer than 8.

*The factory Custom-ICR setting is set for an Amputee with an 8-inch residual femur.

Watch the "Custom-ICR Setting" video at daw-usa.com/videos

- C. Re-tighten the Set Screw before dynamic alignment.

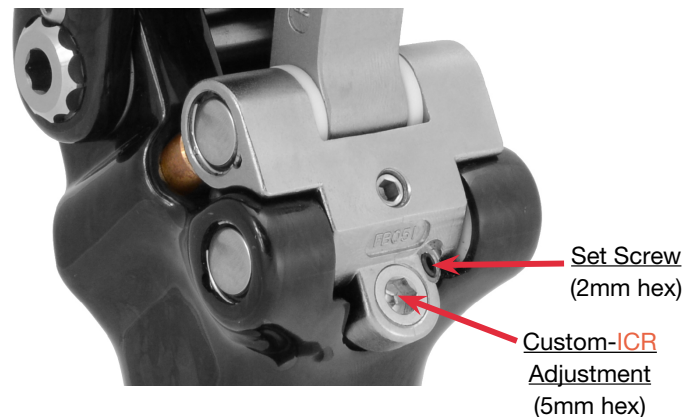

During Dynamic Alignment:

Adjust the setting to your Patient's weak or strong hip extensor strength.

Turn **clockwise** to provide more stability to compensate for weaker hip extensors

or... If patient is hanging up in swing phase,

Turn **counter-clockwise** to provide more efficiency to a Patient with stronger hip extensors.

Return to Factory Setting:

Adjust the Custom-ICR Adjustment Screw (5mm Hex) until it rests flush with its surrounding material

Adjusting Stance Flexion

DAW 5-Bar Stance Flexion Design is engineered to not only smooth the transition from heel strike to mid stance but increase stability at this phase of gait as well¹. Stability increases as more Stance Flexion angle is provided (up to 8°).

NOTE: It is recommended you make this adjustment after making your Custom-ICR™ Stability adjustment.

Adjusting Stance Flexion Cushion and Stability

Equally turn the Stance Flexion Adjustment Screws:

Counter-Clockwise for less resistance, a higher max angle and increased stability at heel strike.

Clockwise for more resistance and a lower max angle.

To Provide Maximum Stance Flexion:

One at a time, turn the Stance Flexion Adjustment Screws

- Counter-clockwise** until the Red Tabs pull out easily.
- Now turn each **clockwise** ¾ of a turn. Adjust equally.
- Verify each Brass Cylinder remains in full contact with the Middle Posterior Axis and the Stance Flexion Adjustment Screws are adjusted equally.

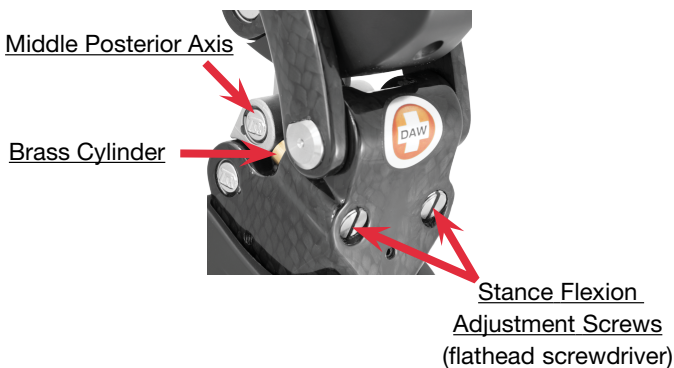

NOTE: After setting Stance Flexion, any change to your previous Custom-ICR setting requires re-adjusting Stance Flexion setting.

¹During stance flexion load at heel strike, the **Instantaneous Center of Rotation (ICR)** shifts further posterior in relation to the Ground Reaction Force Vector. This posterior shift of the ICR produces an increase in geometric stability through heel strike and midstance.

Adjusting Swing Phase Friction

This Knee's Friction Adjustment with Forever-Setting™ eliminates the need to re-adjust your original friction setting in the future.

Two Friction Adjustment Screws apply pressure to a special friction plate against the knee's anterior superior axis.

To Adjust the Friction Setting:

- Flex the knee & remove the Kneecap Screw (3mm hex).
- Turn the Friction Adjustment Screws (4mm hex):

Clockwise to increase friction

Counter-clockwise to decrease friction

NOTE: Adjust both screws equally.

Replace the Kneecap when your friction and swing phase "trigger point" settings are satisfactory.

