

PRACTITIONER'S MANUAL

DAW Industries

4P00-HW™

High Activity True Variable Cadence 4-Bar

Stock # TGK-4P00HW

IMPORTANT:

Adjusting alignment beyond recommended limits described within will adversely affect patient's gait, and could cause premature wear.



HEADQUARTERS:

6610 Nancy Ridge Road
San Diego, CA 92121-2252
Orders: (800) 252-2828 • (858) 622-4962
Fax: (800) 856-8563
www.daw-usa.com

Technical Support
(800) 242-8669

**CENTRAL/EASTERN
DISTRIBUTION CENTER:**
5579-B Chamblee Dunwoody Road
Suite 227
Atlanta, GA 30338-4154
Orders: (800) 824-7192
Fax: (800) 865-8563



4P00-HW™

High Activity True Variable Cadence 4-Bar

Stock # T GK-4P00HW

For K3/K4 individuals of high capability

Benefits:

- ✓ 4-Bar stability & shortening in swing phase
- ✓ Separate extension & flexion adjustments
- ✓ True variable cadence
- ✓ Ultra-Lite Carbon Fiber construction
- ✓ Trouble free, zero maintenance
- ✓ Forever smooth stainless ball bearing axes

Includes: Adjustment Wrench



IMPORTANT:

Read technical information thoroughly before using knee.

Popular Proximal Options

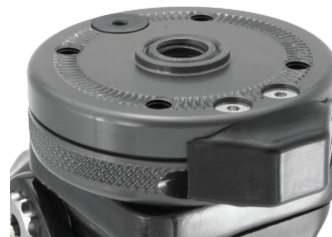

Lo-Pro Rotator™
(#: TKR-01)

Provides Rotational Adjustment
Attach any 4-Hole connector

Suggested L-Codes*: **L5984**



**4-Hole Socket Connector,
Stainless Steel** (#: TSC-PSDS)
Provides Rotational Adjustment

Browse our complete selection of Unique Components at
daw-usa.com/all-connectors

Recommended K3 Foot



K3 Pro-Action™ Foot

Engineered for the low to moderately active K3 Individual

Provides 3 Dynamic Energy Returning Carbon Keel Options
& Multi-Axial Ankle Motion with Rotation.

Suggested L-Codes*: **L5981** **L5986**

*Please refer to the complete reimbursement disclaimer at www.daw-usa.com

Patient Notes

Contents

Page #

Recommended Order of Adjustments 1 (Below)

Build Height 2

Torque Settings 2

Alignment 3

ADJUSTABLE FUNCTIONS

- Extension Stop** (Stability & Swing Phase Trigger Point) 4
- Swing Phase Adjustments** (Flexion & Extension Dampening) . . 5
- Factory Settings of Swing Adjustments. 6
- Extension Assist Adjustment** 7

Replacing or Trimming the Extension Assist Spring 8

Cleaning Pneumatic Components 9

DAW Prosthetic Knee Limited Warranty 10

Specifications 11

Patient Notes 12

Popular Proximal Options (inside back cover)

Recommended Order of Adjustments

1. Extension Stop
2. Flexion Dampening
3. Extension Dampening
4. Extension Assist



For Technical Support call (800)242-8669

© Copyright 2021, DAW Industries, San Diego, CA - All Rights Reserved 01082021



For Technical Support call (800)242-8669

© Copyright 2021, DAW Industries, San Diego, CA - All Rights Reserved 01082021

BUILD HEIGHT

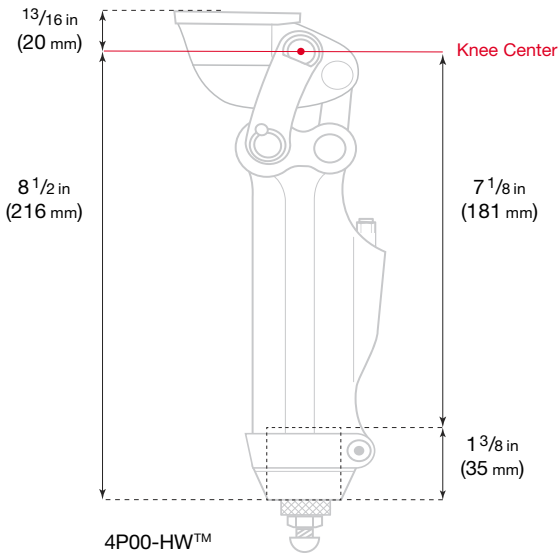

TORQUE SETTINGS

Important:

Use blue Loctite™ 242 on all screws referenced here. It is not recommended to use Ottobock Titanium Pylon. Do not use a spacer for height adjustment. Ensure pylon is cut straight.

It is recommended these torques be checked within 30 days and then 6 months after your delivery of this prosthesis.

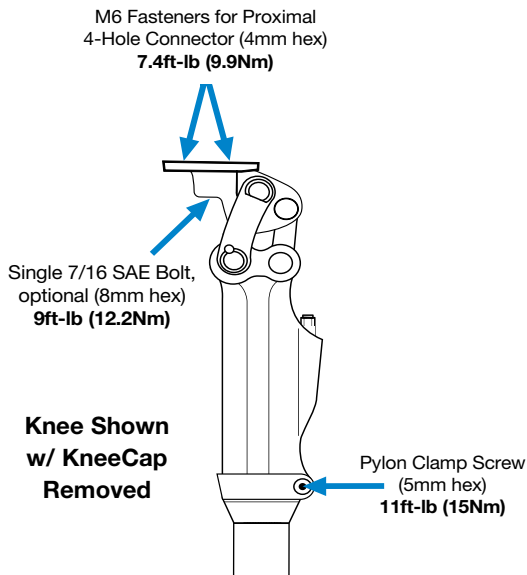

Specifications

Patient profile:

Body weight	Under 300lb (136kg)
Functional level	K3/ K4
Amputation level	Transfemoral or Bi-lateral TF

Knee Specifications:

Stock number	TGK-4P00HW
Max weight limit	300lb (136kg)
Knee weight	2.1 lb (946g)
Swing Controls	Separate DAW Pneumatic™ Extension / Flexion Adjustments, Extension Assist Adjustment & Adjustable Swing Phase Trigger
Stability Control	Adjustable Geometric Stability
Proximal connection	M6 threaded 4-hole or, Unthreaded single hole
Distal connection	30mm tube clamp
Warranty	2 years, upgrade for additional 3 years

DAW Prosthetic Knee Limited Warranty

The knee comes with a Limited Warranty for 2-years. It covers manufacturer defects (excluding wear & tear). An additional 3 years of warranty coverage can be purchased for +15% of the original cost of the knee. See full warranty statement at:

www.daw-usa.com/practitioner-resources/

Weight limit of this knee is 300lb (136kg)

Bumpers are not under warranty.

Tight screws and a straight cut of the tubing are a must. Not following recommended use of components, including weight limit and alignment, will void the warranty. Make sure to read all instructions enclosed with the knee unit.

All repairs on the knee module must be done by a factory-trained DAW technician. Any disassembly done on the knee during the warranty period(s) will void the warranty (excluding disassembly of the extension spring housing).

Service Under Warranty

For all component repairs call DAW Industries right away. We will ship a replacement knee the same day, which will become your patient's new knee. The replacement component is under warranty for the time remaining on the original component.

The overnight shipping charge will be credited upon receipt of the failed knee component.

Service Outside of Warranty

Knees not under warranty may be repaired by DAW. While any unwarranted knee is being serviced, DAW will provide a rental knee subject to availability. The DAW rental fee is listed in the price list under each knee. The rental fee covers the period DAW takes to complete the repair with ten (10) days allowed for shipping in both directions. The same rental fee will be charged every 30 days passed the initial rental fee period.

For any repair you must first contact our Technical Services at 1(800)242-8669. This will allow DAW to best understand the issue. Our Technical Support will immediately assess if the repair qualifies as a "minor" or "substantial" repair. A "minor" repair will be completed, as a courtesy, free of charge (you will just pay for return shipping). A "substantial" repair will be billed at a flat rate according to knee model. Upon return of your repaired knee, you will be invoiced for the repair charge, if any. When DAW receives the rental knee, your account will be credited for the value of the returned knee (Gold Preferred+ = FREE rental; Preferred = 33% off).

In the event your knee is unrepairable, you will be notified immediately. The rental must then be returned to DAW, 2nd day, within five (5) working days. The rental fee may be applied toward the purchase of a new DAW knee.



For Technical Support call (800)242-8669

© Copyright 2021, DAW Industries, San Diego, CA - All Rights Reserved 01082021

RECOMMENDED BENCH & STATIC ALIGNMENT

Standard alignment procedure must be observed to obtain the maximum benefits offered by this knee. All alignment references should be taken from the center of the anterior superior knee axis (commonly referred to as the Knee Center).

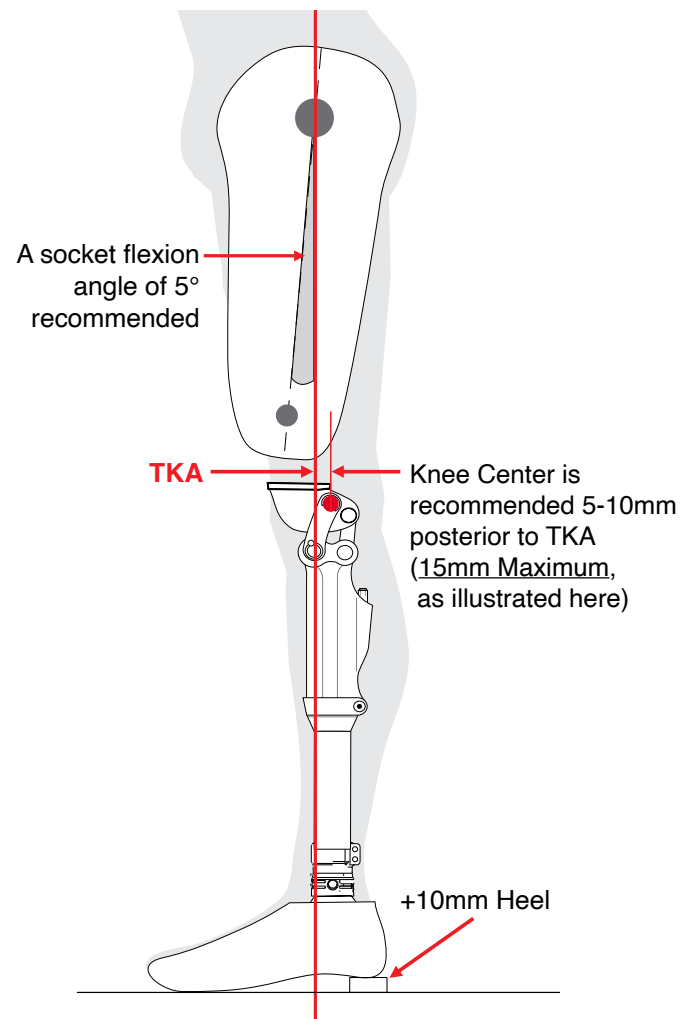

For Technical Support call (800)242-8669

© Copyright 2021, DAW Industries, San Diego, CA - All Rights Reserved 01082021

Adjusting the Extension Stop Bumper

(Geometric Stability & Swing Phase Trigger Point)

Adjusting the Extension Stop Bumper will affect both the Knee's Stability and "Trigger Point" of Swing Phase. The maximum adjustment is 2°.

NOTE: This adjustment will affect socket flexion slightly.

Adjusting the Extension Stop Bumper Screw:

- Flex the knee and remove the Kneecap Screw (3mm hex), and remove the Kneecap.
- Loosen the Set Screw (2mm hex)
- Turn the Extension Stop Bumper Screw (6mm hex)
 - Clockwise** for earlier swing-phase initiation (& less stance-phase stability)
 - Counter-clockwise** for later swing-phase initiation (& more stance-phase stability)
- Retighten the Set Screw (**Hand Tighten**).
- Replace the Kneecap when your swing-phase trigger point setting is satisfactory (**Hand Tighten**).

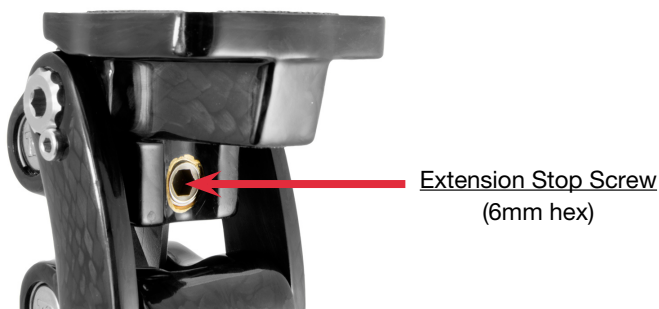
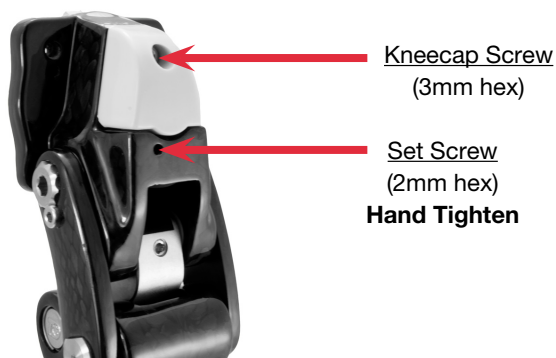

Cleaning Pneumatic Components

- Using the Swing Adjustment Wrench (or 9mm wrench), completely remove the Flexion Knob. Turn the Knob **counter-clockwise** until it no longer appears to be unthreading. The Knob pulls out of its chamber with a small amount of force.
- With the Knob removed, flex the Knee quickly & repeatedly to clear out any debris from the air passage. Air should flow smoothly with no restriction.
- Using a Q-Tip, clean the chamber from which the Knob was removed. The entire chamber should be dry.
- Remove the Extension Screw (3mm Hex) from the Knob. Remove the Needle and clean it of any debris or lubricant.
- Apply a very light coat of wheel-bearing grease to the Knob O-ring. Be sure the Needle remains dry.
- Return the Needle to the Knob. Do not yet return the Screw to the Knob. Press the Knob and Needle back into the chamber of the knee. You will hear a "click" as the Knob seats back into the chamber.
- Turn the Flexion Knob **clockwise**. Initially, apply a small amount of downward force while you turn to ensure the threads catch. Gently screw it in until it stops. Do not tighten.
- Turn the Knob **counter-clockwise** 2 rotations (the factory setting for Extension).
- While holding the Knob stationary with the Swing Adjustment Wrench (or 9mm wrench), screw the Extension Screw back into the Knob until 1 thread shows above the Knob (the factory setting for Flexion).

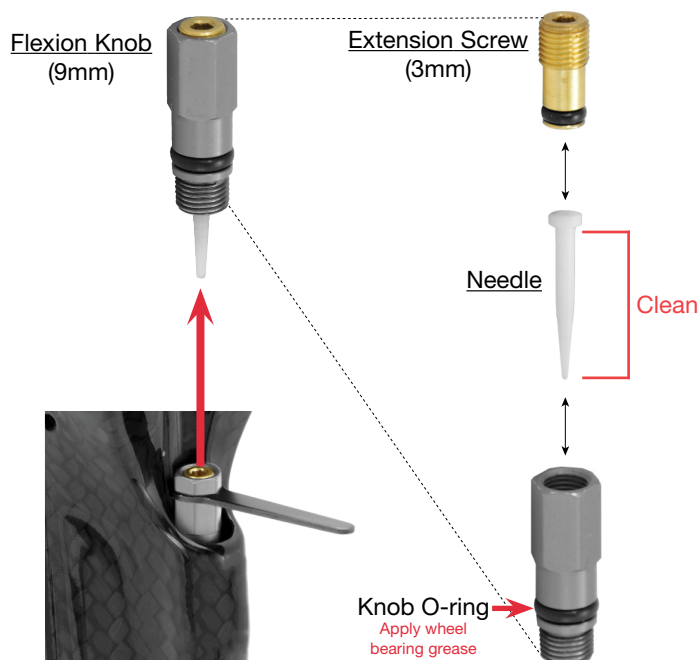

Replacing or Trimming the Extension Assist Spring

For highly capable Amputees, it may be necessary to replace or trim the Extension Assist Spring.

To replace the **Extension Assist Spring**:

- A. Completely remove the Pylon Clamp Screw (5mm hex).
- B. Remove the pylon.
- C. Flex the knee to full flexion.
- D. Using a 12mm wrench, or crescent wrench, twist the Lock Nut ① **clockwise**, the Spring Housing ② will extend out of the knee as you twist the Lock Nut.
- E. You can now pull the Spring ③ out of the Housing ②.
- F. Insert your new Spring ③ into the Housing ②.
- G. Unflex the knee to full extension and return the housing to the knee making sure the groove for the Pylon Clamp Screw lines up properly.

After returning the Pylon. Retighten Pylon Clamp Screw (5mm hex) to **11ft-lb (15Nm)**

To Trim the Extension Assist Spring:

Complete steps A. through E. above

Using a grinding wheel, trim one or two coils (maximum) off one end of the Spring. Smooth the trimmed end. Return the Spring to the housing, **trimmed end down**. Continue with step G. above.



Adjusting Swing Phase Controls (Flexion & Extension Dampening)

It is recommended your Patient take their first steps slowly!

This knee is engineered to conserve your Patient's energy & strength throughout the day. Very little energy is required to initiate gate.

The DAW Pneumatics™ Knob-and-Screw-Adjustment provides exceptionally precise control of heel rise and extension dampening. Perform these adjustments in $\frac{1}{8}$ -turn increments.

Needed for This Adjustment:

- ✓ 3mm hex key
- ✓ Swing Adjustment Wrench (included) or a 9mm wrench

NOTE: Excessive adjustment of Extension Screw can jam needle pin, eliminating full range-of-motion resistance control.

It is recommended to make your Extension Adjustment first, *then* your Flexion Adjustment. Repeat adjusting Extension *then* Flexion as needed.

Adjusting Extension Dampening:

In $\frac{1}{8}$ -turn increments, turn the brass Extension Screw:
Clockwise to increase resistance
Counter-Clockwise to decrease resistance

Adjusting Flexion Dampening:

While holding the Extension Screw stationary (3mm hex key), in $\frac{1}{8}$ -turn increments turn the Flexion Knob:
Clockwise to increase resistance
Counter-Clockwise to decrease resistance

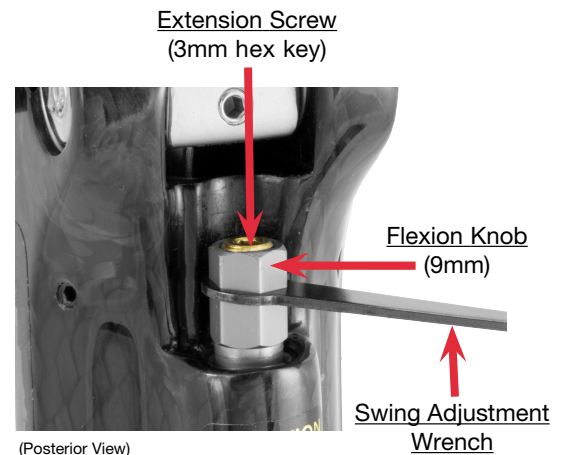

Returning Extension & Flexion Adjustments to Factory Settings

- A. Unscrew and remove the brass Extension Screw (3mm Hex) from the center of the Flexion Knob.
- B. Using the included Swing Adjustment Wrench (or a 9mm wrench), gently screw the Flexion Knob **clockwise** until it stops. Do not tighten.
- C. Now turn the Knob **counter-clockwise 2 full rotations**.
- D. While holding the Knob stationary, screw the Extension Screw back into the Knob (**fig. 1**) until one thread shows above the Knob (**fig. 2**).

The knee's Flexion & Extension Controls are now at their factory settings.

Fig. 1

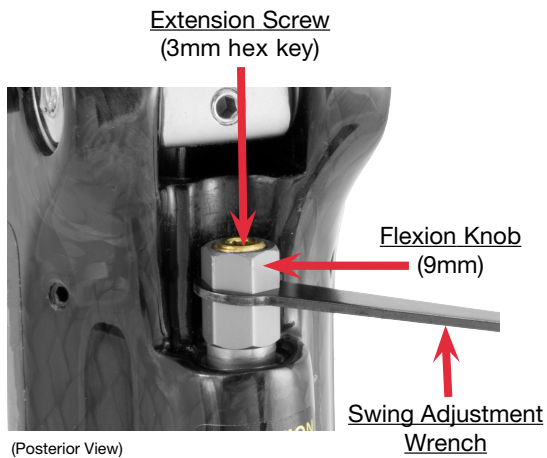
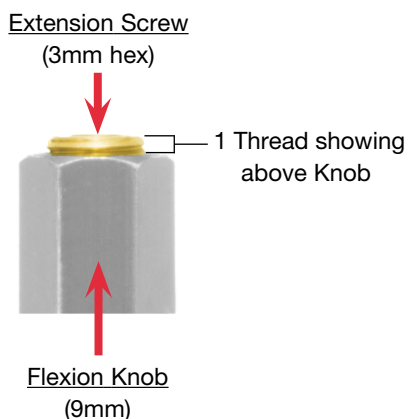

Fig. 2



Adjusting Extension Assist

To Adjust Extension Assist:

- A. Loosen the Pylon Clamp Screw (5mm hex) and remove the Pylon
- B. Loosen the Lock Nut (12mm wrench)
- C. Turn the Extension Assist Control Screw (5mm hex):
Clockwise to increase extension assist
Counter-clockwise to decrease extension assist
- D. Re-tighten the Lock Nut, **Hand Tighten** (12mm wrench)
 After returning the pylon, re-tighten Pylon Clamp Screw to **11ft-lb (15Nm)**.

