

PRACTITIONER'S MANUAL

DAW Industries

30°-Stop™ “Original”

30-Degree Flexion Stop & Extension Assist

Stock #: TK-4002

IMPORTANT:

Adjusting alignment beyond recommended limits described within will adversely affect patient's gait, and could cause premature wear.



HEADQUARTERS:

6610 Nancy Ridge Road
San Diego, CA 92121-2252
Orders: (800) 252-2828 • (858) 622-4962
Fax: (800) 856-8563
www.daw-usa.com

Technical Support
(800) 242-8669

CENTRAL/EASTERN

DISTRIBUTION CENTER:

5579-B Chamblee Dunwoody Road
Suite 227
Atlanta, GA 30338-4154
Orders: (800) 824-7192
Fax: (800) 865-8563



30°-Stop™ “Original”

30-Degree Flexion Stop & Extension Assist

Stock #: TK-4002

Engineered to build confidence in K1/K2 individuals

Benefits:

- ✓ Optional 30-degree stop, manual release to sit
- ✓ Allows for normal walking without knee buckling
- ✓ Adjustable friction & extension assist
- ✓ Cost-effective aluminum construction
- ✓ Proven durability & reliability

Includes: Manual Stop Release Assembly
& Cable End Cap



IMPORTANT:

Read technical information thoroughly before using knee.



Popular Proximal Options

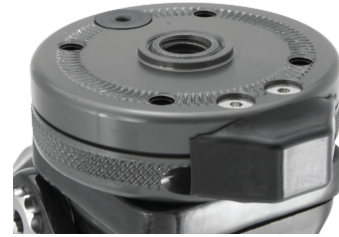

Lo-Pro Rotator™
(#: TKR-01)

Provides Rotational Adjustment
Attach any 4-Hole connector

Suggested L-Codes*: **L5984**



**4-Hole Female Pyramid w/ Rotation,
Titanium** (#: GUPT-F4HROT)
Provides Angular & Rotational Adjustment

Browse our complete selection of Unique Components at
daw-usa.com/all-connectors

Recommended K2 Foot



K2 Feather-Lite™ Foot

Engineered for the K2 Individual Requiring mobility & safety

Provides 2 Flexible Keel Options &
Multi-Axial Ankle Motion with Rotation

Suggested L-Codes*: **L5972** **L5986**

*Please refer to the complete reimbursement disclaimer at www.daw-usa.com



Patient Notes

Contents

Page #

Recommended Order of Adjustments 1 (Below)

Build Height 2

Torque Settings 2

Alignment 3

ADJUSTABLE FUNCTIONS

Extension Stop (Stability & Swing Phase Trigger Point) 4

Swing Phase Friction Adjustment with Forever-Setting™ 5

Extension Assist Adjustment 6

Replacing or Trimming the Extension Assist Spring 7

Securing the Manual Stop
Release Assembly to the Socket 8

Disengaging the 30° Flexion Stop 9

DAW Prosthetic Knee Limited Warranty 10

Specifications 11

Patient Notes 12

Popular Proximal Options (inside back cover)

Recommended Order of Adjustments

1. Extension Stop (Geometric Stability)
2. Swing Phase Friction
3. Extension Assist



For Technical Support call (800)242-8669

© Copyright 2021, DAW Industries, San Diego, CA - All Rights Reserved 01082021



For Technical Support call (800)242-8669

© Copyright 2021, DAW Industries, San Diego, CA - All Rights Reserved 01082021

BUILD HEIGHT

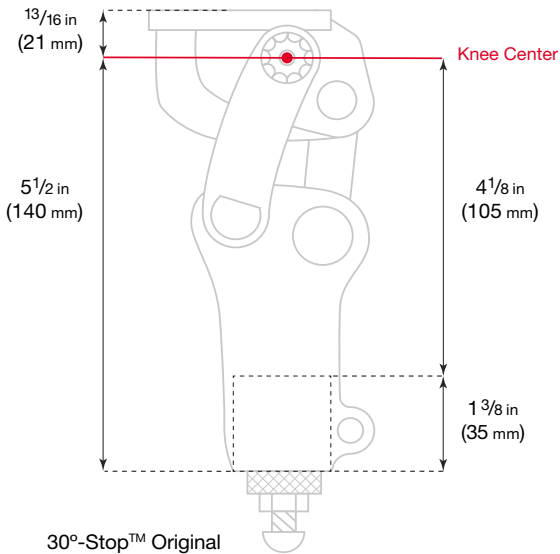

TORQUE SETTINGS

Important:

Use blue Loctite™ 242 on all screws referenced here. It is not recommended to use Ottobock Titanium Pylon. Do not use a spacer for height adjustment. Ensure pylon is cut straight.

It is recommended these torques be checked within 30 days and then 6 months after your delivery of this prosthesis.

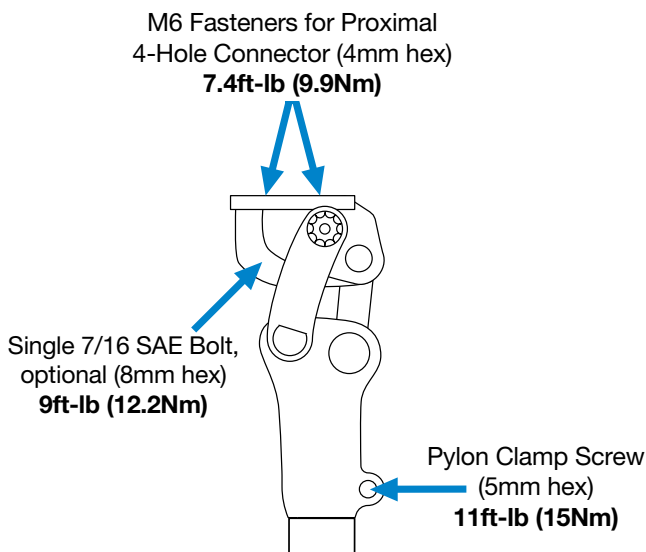

Specifications

Patient profile:

Body weight	Under 220lb (100kg)
Functional level	K1 / K2
Amputation level	Transfemoral, Bi-lateral TF or Hip Disarticulation

Knee Specifications:

Stock number	TK-4002
Max weight limit	220lb (100kg)
Knee weight	1.94lb (882g)
Swing controls	Auto-Readjusting Constant Friction, Extension Assist & Adjustable Swing Phase Trigger
Stability controls	Optional 30° Flexion Stop & Adjustable Geometric Stability
Proximal connection	M6 threaded 4-hole or, Unthreaded single hole
Distal connection	30mm tube clamp
Warranty	2 years, upgrade for additional 3 years

DAW Prosthetic Knee Limited Warranty

The knee comes with a Limited Warranty for 2-years. It covers manufacturer defects (excluding wear & tear). An additional 3 years of warranty coverage can be purchased for +15% of the original cost of the knee. See full warranty statement at:

www.daw-usa.com/practitioner-resources/

Weight limit of this knee is 220lb (100kg)

Bumpers are not under warranty.

Tight screws and a straight cut of the tubing are a must. Not following recommended use of components, including weight limit and alignment, will void the warranty. Make sure to read all instructions enclosed with the knee unit.

All repairs on the knee module must be done by a factory-trained DAW technician. Any disassembly done on the knee during the warranty period(s) will void the warranty (excluding disassembly of the extension spring housing).

Service Under Warranty

For all component repairs call DAW Industries right away. We will ship a replacement knee the same day, which will become your patient's new knee. The replacement component is under warranty for the time remaining on the original component.

The overnight shipping charge will be credited upon receipt of the failed knee component.

Service Outside of Warranty

Knees not under warranty may be repaired by DAW. While any unwarranted knee is being serviced, DAW will provide a rental knee subject to availability. The DAW rental fee is listed in the price list under each knee. The rental fee covers the period DAW takes to complete the repair with ten (10) days allowed for shipping in both directions. The same rental fee will be charged every 30 days passed the initial rental fee period.

For any repair you must first contact our Technical Services at 1(800)242-8669. This will allow DAW to best understand the issue. Our Technical Support will immediately assess if the repair qualifies as a "minor" or "substantial" repair. A "minor" repair will be completed, as a courtesy, free of charge (you will just pay for return shipping). A "substantial" repair will be billed at a flat rate according to knee model. Upon return of your repaired knee, you will be invoiced for the repair charge, if any. When DAW receives the rental knee, your account will be credited for the value of the returned knee (Gold Preferred+ = FREE rental; Preferred = 33% off).

In the event your knee is unrepairable, you will be notified immediately. The rental must then be returned to DAW, 2nd day, within five (5) working days. The rental fee may be applied toward the purchase of a new DAW knee.



For Technical Support call (800)242-8669

© Copyright 2021, DAW Industries, San Diego, CA - All Rights Reserved 01082021

RECOMMENDED BENCH & STATIC ALIGNMENT

Standard alignment procedure must be observed to obtain the maximum benefits offered by this knee. All alignment references should be taken from the center of the anterior superior knee axis (commonly referred to as the Knee Center).

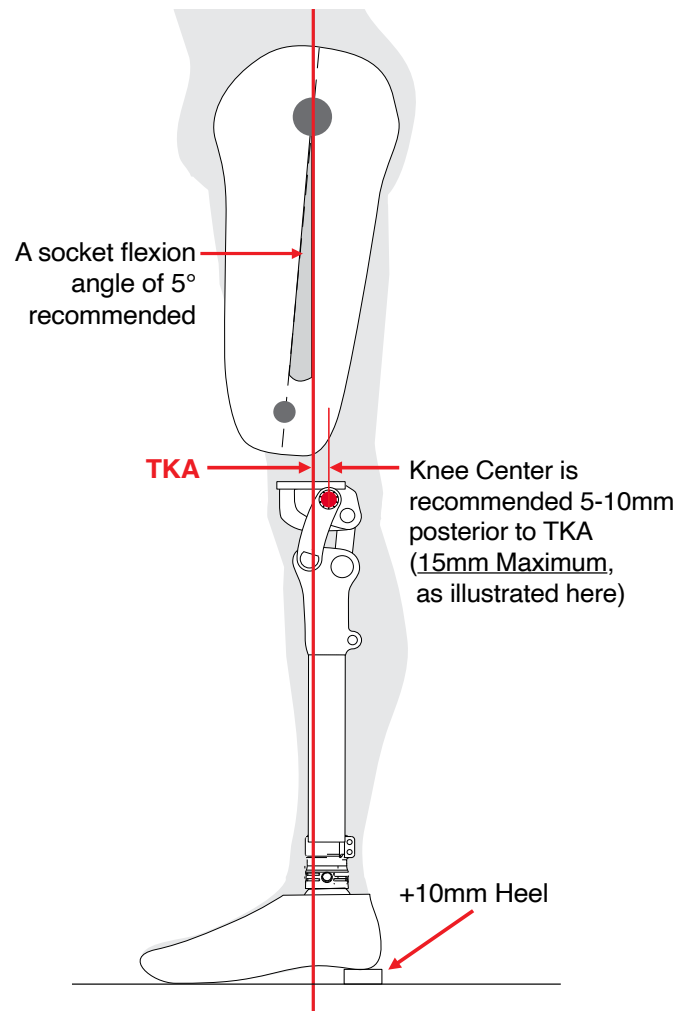

For Technical Support call (800)242-8669

© Copyright 2021, DAW Industries, San Diego, CA - All Rights Reserved 01082021

Adjusting the Extension Stop Bumper

(Geometric Stability & Swing Phase Trigger Point)

To customize the knee's stability and "trigger point" of swing-phase, adjust the Extension Stop Screw. Max adjustment is 2°.

Note: This adjustment will affect socket flexion.

To access the Extension Stop Screw:

- A. Flex the knee and remove the Kneecap Screw (3mm hex)
- B. Turn the Extension Stop Screw (6mm hex):
 - Clockwise** for less stability
(& earlier swing-phase initiation)
 - Counter-clockwise** for more stability
(& later swing-phase initiation)
- C. Replace the Kneecap after completing your Swing Phase Friction Adjustment. (page 5)

Kneecap Screw
(3mm hex)



Extension Stop Screw
(6mm hex)

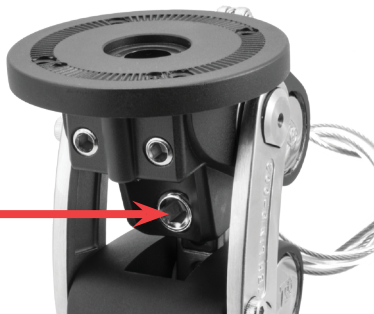

Disengaging the 30° Flexion Stop

The 30° Flexion Stop mechanism can be permanently disengaged by performing the following steps:

- A. Pull the Stop Release Lever up into the unlocked position and hold in place.
- B. Tighten the Lever Locking Screw (2.5mm hex).
- C. The lock can easily be reengaged by loosening the Lever Locking Screw.

Stop Release Lever Lever Locking Screw
(2.5mm hex)



Securing the Manual Stop Release Assembly to the Socket

Before proceeding with the final lamination, locate the optimum position for the “J-Handle”. (The most common location is positioned relative to the patient’s pants pocket.)

- A. Unscrew the Threaded Washer, place in between layers of the laminating materials.
- B. Laminate the socket as usual.
- C. Once the resin is cured, use a hot nail to clean the threads in the Threaded Washer.
- D. Secure the “J-Handle” Screw to the Threaded Washer.
- E. Loosen the Cable Locking Screws (2mm hex).
- F. Adjust the length of the Cable, tighten the Cable Locking Screws.
- G. Cut off the excess cable and swage the End Cap.

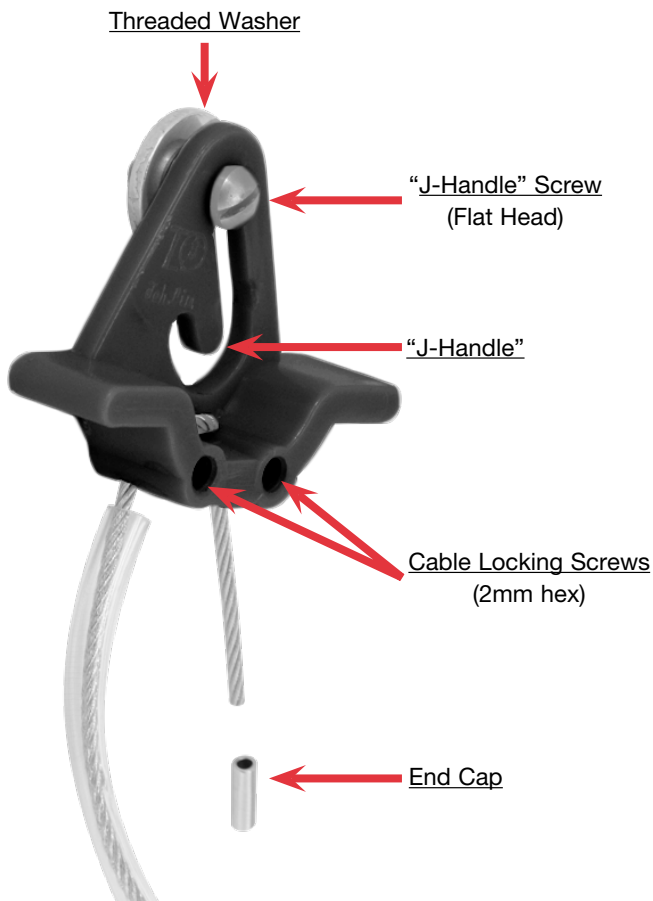

Adjusting Swing Phase Friction

This Knee’s Friction Adjustment with Forever-Setting™ eliminates the need to re-adjust your original friction setting in the future.

Two Friction Adjustment Screws apply pressure to a special friction plate against the knee’s anterior superior axis.

To Adjust the Friction Setting:

- A. Flex the knee & remove the Kneecap Screw (3mm hex).
- B. Turn the Friction Adjustment Screws (4mm hex):

Clockwise to increase friction

Counter-clockwise to decrease friction

NOTE: Adjust both screws equally.

Replace the Kneecap when your friction and swing phase “trigger point” settings are satisfactory.

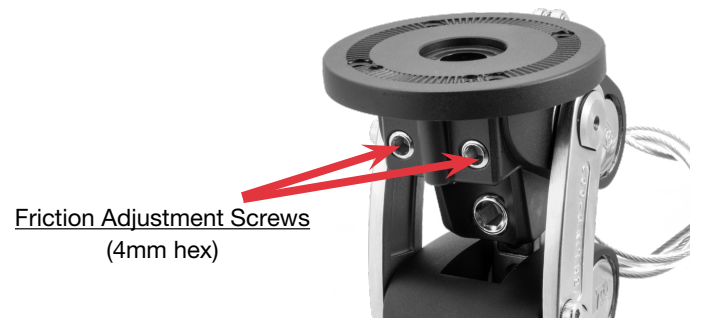

Adjusting Extension Assist

To Adjust Extension Assist:

- Loosen the Pylon Clamp Screw (5mm hex) and remove the Pylon
- Loosen the Lock Nut (12mm wrench)
- Turn the Extension Assist Control Screw (5mm hex):
Clockwise to increase extension assist
Counter-clockwise to decrease extension assist
- Re-tighten the Lock Nut, **Hand Tighten** (12mm wrench). After returning the pylon, re-tighten Pylon Clamp Screw to **11ft-lb (15Nm)**.



Replacing or Trimming the Extension Assist Spring

To replace the Extension Assist Spring:

- Loosen the Pylon Clamp Screw (5mm hex).
- Remove the pylon.
- Completely remove the Extension Assist Control Screw ① (5mm hex).
- Feed a 2.5mm hex key through the holes of the Spring Housing ②. Using the torque provided by the hex key, unscrew the housing.
- Pull the white Piston ③ out of the housing. The Spring ④ is pressed on the Piston's distal end.
- Unclip the Piston and Force Plate ⑤ from the Spring, transfer them to your new Spring. Return the Spring Assembly, Force Plate end down, to the housing.
- Re-screw the Housing into the knee, hand tighten.
- Re-screw the Extension Assist Control Screw back in until you feel it make contact with the Force Plate (this is your new minimum setting).

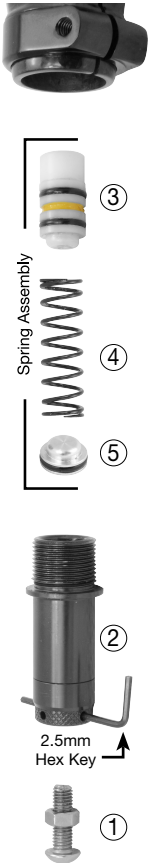

To trim the Extension Assist Spring?

Follow steps A. through E. above, then,

Unclip the Force Plate ⑤ & Piston ③ from the Spring.

Using a grinding wheel, trim one or two coils (maximum) off one end of the spring. Smooth the trimmed end. Press the Force Plate into the mouth of the housing. Press the Piston onto the uncut end of the Spring. Return the Spring & Piston to the housing, **trimmed end down**, pushing the Force Plate down into the housing.

Continue with steps G. and H. above.